



Print & Apply Labeler with Intelligent Motion™ technology

Videojet® 9550 Front of Pack

The Videojet 9550 Front of Pack is a smarter print and apply labeler that is designed to target zero unscheduled downtime and can help reduce costs and errors in case coding operations.

Videojet Intelligent Motion™ technology automatically and precisely controls the entire system, helping to remove operational downtime often caused by label jams and snagged labels. A robust and simply designed applicator makes it easy to use, plus an integrated pack detect feature helps ensure accurate label placement.

The 9550 with Front of Pack applicator is ideal for cases or shrink wrapped products where the label must be applied on the leading panel of the pack.

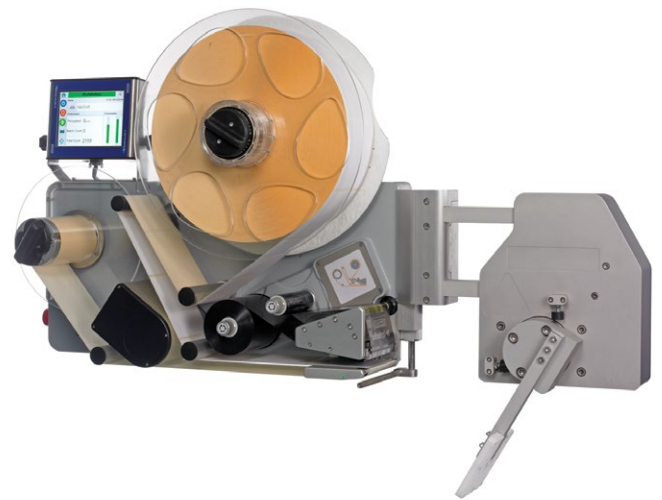

Uptime Advantage

- Optimize maintenance labor by removing common wear and adjustment parts
- Integrated pack/case detect and applicator home/extended sensors fitted as standard
- Intelligent Motion™ technology precisely controls label feed with no clutches and no nip roller
- Clean, robust design protects components during operation to help maximize uptime

Built-in productivity

- Optimize print quality and printhead life with automatic printhead pressure regulation
- Track performance and help achieve OEE improvements with on-screen diagnostics

Code Assurance

- Virtually eliminate operator errors, helping to ensure products are coded correctly with built-in Code Assurance software features
- Minimize operator touches with on-board label database for accurate job selection
- Automate bar code creation by linking data from multiple text fields

Simple usability

- Perform label and ribbon changes in less than 60 seconds through simplest web path
- Quickly check status and select jobs with single, intuitive interface that makes operation easy

Videojet® 9550 with Front of Pack

Print & Apply Labeler with Intelligent Motion™ technology

Application method

Top mount swing arm with 12.0" (305mm) reach

Print technology

Thermal Transfer printing with Intelligent Motion™ Ribbon Drive and Direct Chemi-Thermal
107mm printhead

Print resolution

300dpi / 200dpi emulation mode

Printhead health monitoring

Tool-free quick release printhead replacement

Print speed

1.6 – 19.7inches/sec (40 – 500mm/sec)

Throughput

Up to 60 packs per minute (depending on label size, telescopic stroke)
Recommended max conveyor speed 98.4ft/min (30m/min)

Ribbon specification

Width: 2.2" (55mm), 3.0" (76mm) and 4.3" (110mm) (standard)
Capacity: Up to 830m, including automatic ribbon save (<1mm ribbon gap between successive prints irrespective of label size or speed)
Low Ribbon and End of Ribbon detection with predicted changeover time built in as standard

Label specification

Label Width 2.0" to 4.5" (50mm to 115mm)
Label Length 2.0" to 4.7" (50mm to 120mm)
Capacity: Up to 400mm spool diameter (typically delivers over 9000 typical GS1 bar code labels per roll)
Low Labels and End of Label Reel detection, with predicted changeover time built in as standard Automatic adjustment for label/backing type and label size 400MB on-board label database, sufficient for 25,000 typical GS1 bar code label design

Tamp sizes

Standard: 100mm x 100mm
Optional: 50mm x 120mm, 75mm x 120mm, 100mm x 50mm, 100mm x 70mm, 100mm x 150mm

Print capabilities

Full downloadable font support using TrueType® fonts (including multiple languages and Unicode support); fixed, variable and merged text fields; flexible date/time formats; flexible shift code formats; auto best before date calculations and concession management; calendar rules; auto incrementing decrementing text, counters and bar codes; multiple graphic formats supported (up to maximum print area); link fields to databases; scalable text and text blocks

Bar codes supported

EAN 8, EAN 13, UPC-A, UPC-E, Code 39, GS1-128, Code 128, ITF, RSS (including 2D composite codes); others available upon request

Connectivity

Ethernet, Power-over-Ethernet, RS232, Configurable I/O (24V, PNP and volt free)
USB (for backup/restore and label upload), remote Control Videojet 9550 via a web browser

Communications Protocols

Compatible with Videojet Clarisuite™ software
Videojet binary and simple-ASCII protocols
Compatible with any label design software which supports Zebra or Sato print engines
Zebra (ZPL), Sato (SBPL) and Markem-Image (Cimcomms) protocol support

Interface

CLARITY™ Controller with Interactive on-board video tutorials

Language Capabilities

Arabic, Bulgarian, Czech, Danish, English, German, Greek, Finnish, French, Hebrew, Hungarian, Italian, Japanese, Korean, Dutch, Norwegian, Polish, Portuguese, Romanian, Russian, Serbian, simplified Chinese, Slovak, Spanish, Swedish, Thai, Turkish, Traditional Chinese, Vietnamese

Compressed Air

6 Bar. 90psi, uncontaminated

Power Consumption

90-260 VAC (115W at 50 packs per minute)

Operating Environment

Temperature Range: 41-104°F (5-40°C)
Humidity: 20-85% Relative, non-condensing

Weight

Complete system - 112.44lbs (51kg)
Front of Pack applicator - 24.25lbs (11kg)
9550 with labels and ribbon - max 88.19lbs (40 kg)

Applicable certifications

CE, TÜV

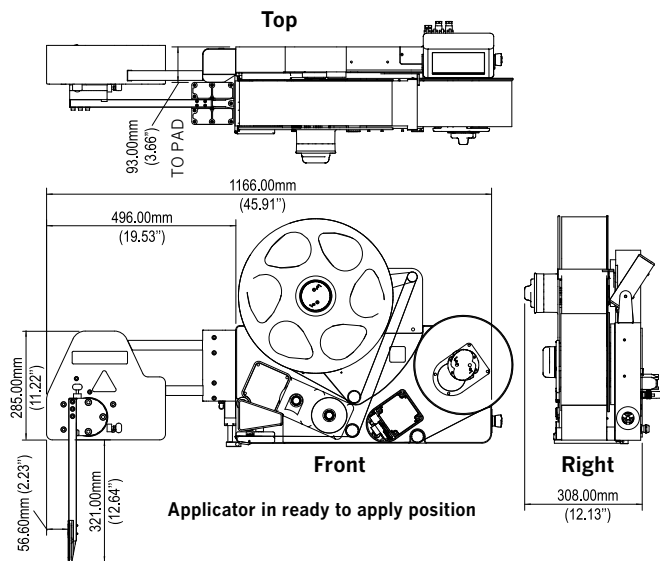

Call **800-843-3610**

Email **info@videojet.com**

or visit **www.videojet.com**

Videojet Technologies Inc.

1500 Mittel Blvd. Wood Dale IL 60191 / USA

©2015 Videojet Technologies Inc. — All rights reserved.

Videojet Technologies Inc.'s policy is one of continued product improvement. We reserve the right to alter design and/or specifications without notice. TrueType is a trademark of Apple Inc. in the U.S. and other countries.

Part No. SL000616
ss-9550-front-of-pack-us-0515
Printed in U.S.A.

