

X-ray Inspection System

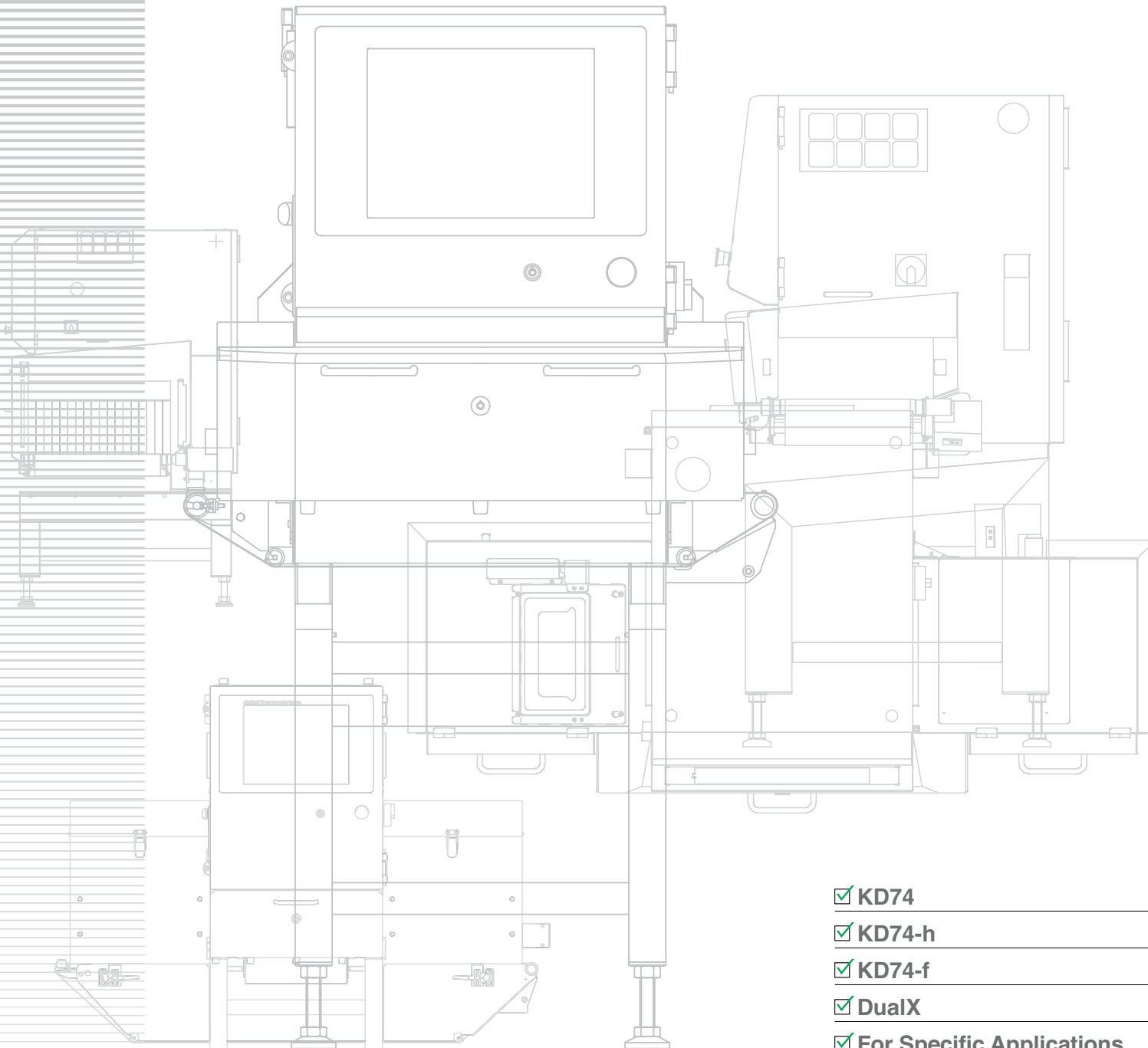

- ✓ KD74
- ✓ KD74-h
- ✓ KD74-f
- ✓ DualX
- ✓ For Specific Applications

X-ray Inspection System



Line up

Standard

KD74 series

Highly versatile system with a proven track record suits a wide range of packaged products. Simultaneous inspection including shape analysis, missing item and package integrity inspection are available.

Products	<input checked="" type="checkbox"/> Dry products	<input checked="" type="checkbox"/> Wet products
Protection class	<input type="checkbox"/> IP40	<input checked="" type="checkbox"/> IP66
X-ray output	<input type="checkbox"/> Low (max. 100W)	<input checked="" type="checkbox"/> Middle to High (max. 210W) <input type="checkbox"/> High (max. 350W)
Product range	<input checked="" type="checkbox"/> Size variations	

High Definition

KD74-h series

High accuracy detection technology detects a 0.2 diameter metal sphere. Suitable for soft contaminants that are of low-density, such as bone and plastics, as well as for minute metal particles.

Products	<input checked="" type="checkbox"/> Dry products	<input checked="" type="checkbox"/> Wet products
Protection class	<input type="checkbox"/> IP40	<input checked="" type="checkbox"/> IP66
X-ray output	<input type="checkbox"/> Low (max. 100W)	<input type="checkbox"/> Middle to High (max. 210W) <input checked="" type="checkbox"/> High (max. 350W)
Product range	<input checked="" type="checkbox"/> For metal particles	<input checked="" type="checkbox"/> For low density contaminants <input checked="" type="checkbox"/> Size variations

Entry

KD74-f series

With low X-ray output and simple construction, this series are suitable for dry products.

Products	<input checked="" type="checkbox"/> Dry products	<input type="checkbox"/> Wet products
Protection class	<input checked="" type="checkbox"/> IP40	<input type="checkbox"/> IP66
X-ray output	<input checked="" type="checkbox"/> Low (max. 100W)	<input type="checkbox"/> Middle to High (max. 210W) <input type="checkbox"/> High (max. 350W)
Product range	<input checked="" type="checkbox"/> Size variations	

DualX

Analyzing two different x-ray energy signals, it clearly distinguishes contaminants from products. Performs accurate inspection of low density bones in meat and overlapping products.

Products	<input checked="" type="checkbox"/> Dry products	<input checked="" type="checkbox"/> Wet products
Protection class	<input type="checkbox"/> IP40	<input checked="" type="checkbox"/> IP66
X-ray output	<input type="checkbox"/> Low (max. 100W)	<input checked="" type="checkbox"/> Middle to High (max. 210W) <input checked="" type="checkbox"/> High (max. 350W)
Product range	<input checked="" type="checkbox"/> High power	<input checked="" type="checkbox"/> Low power

For Specific Applications

X-ray systems in a variety of configurations offered to fit specific inspection requirements.

- Large bags and cartons
- Tall products
- Sanitary design
- Pipe type

Model Selection List

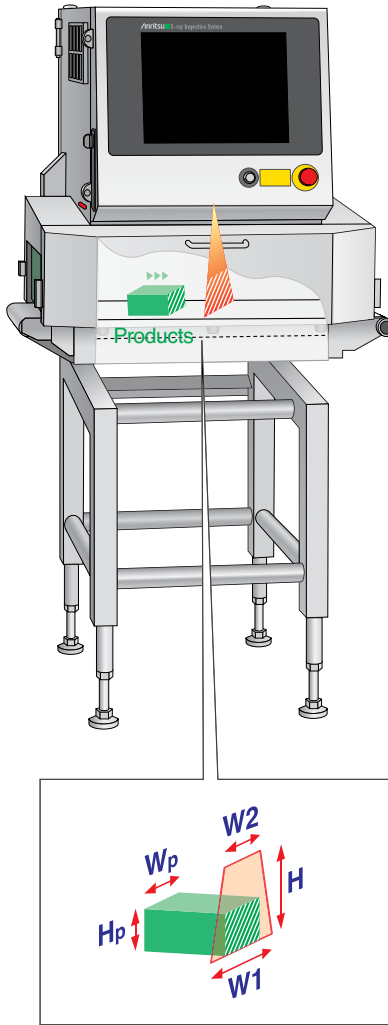

Model	Detection area (Units : mm)	Page
KD7405AWH/ADWH /BWH/BDWH		4
KD7405CWT/DWT KD7405DWH		Effective detection width = $240 - \frac{80 \times H_p}{120}$
KD7405KP/KDP		Effective detection height = $\frac{120 \times (240 - W_p)}{80}$
KD7405ABWH		6
KD7405ACWH		Effective detection width = $240 - \frac{40 \times H_p}{50}$
KD7405KCP		Effective detection height = $\frac{50 \times (240 - W_p)}{40}$
KD7416AWH/ADWH /BWH/BDWH		5
KD7416DWH		Effective detection width = $390 - \frac{110 \times H_p}{150}$
KD7416AWZE/ADWZE KD7416DWZ		Effective detection height = $\frac{150 \times (390 - W_p)}{110}$
KD7416ABWH		6
KD7416ACWH		Effective detection width = $390 - \frac{35 \times H_p}{50}$
KD7416ACWZE		Effective detection height = $\frac{50 \times (390 - W_p)}{35}$
KD7417BWH		5
KD7417DWH		Effective detection width = $390 - \frac{160 \times H_p}{220}$
KD7447DW KD7447DWE KD7447FWE		9
		Effective detection width = $590 - \frac{180 \times H_p}{250}$
KD7337AWH1 KD7337AWH2		13
		Effective detection width = $690 - \frac{180 \times H_p}{250}$
KD7416AM		14
		Effective detection width = $690 - \frac{180 \times H_p}{250}$
KD7416ACM		15
		Effective detection width = $365 - \frac{35 \times H_p}{50}$
KD7478AWH KD7478BWH		15
		<ul style="list-style-type: none"> ● When $H_p \leq 237$: Effective detection width = 150 ● When $237 < H_p \leq 307$: Effective detection width = $150 \times \frac{307 - H_p}{70}$
	<ul style="list-style-type: none"> ● When $H_p \leq 237$: Effective detection height = 307 ● When $237 < H_p \leq 307$: Effective detection height = $307 - \frac{70 \times W_p}{150}$ 	16

Note: Any one of the pass heights can be selected.

Standard

KD74 series

For Packaged Products

KD7405AWH/ADWH/BWH/BDWH

Maximum width Maximum height
 Product size: 240 mm × 120 mm



KD7405AWH

External Dimensions

KD7405AWH KD7405ADWH *
 KD7405BWH KD7405BDWH *

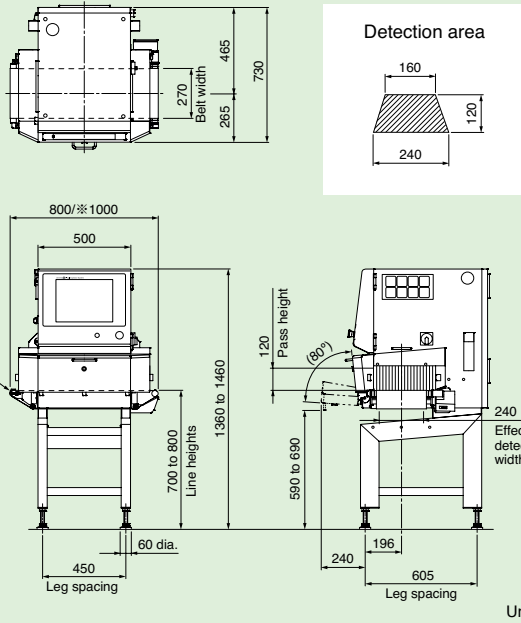

Units:mm

The conveyor is lengthened from 800 to 1000 for smooth product transfer.

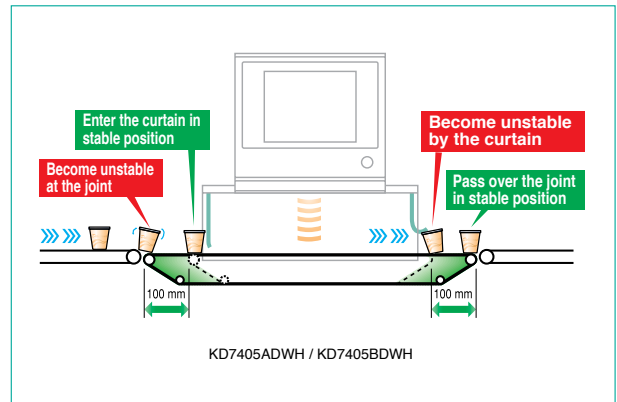

Specifications

Model	KD7405AWH	KD7405ADWH	KD7405BWH	KD7405BDWH
Detection sensitivity ¹	Fe sphere and SUS sphere 0.3 mm dia., SUS wire 0.2 mm dia.x 2 mm long			
X-ray output	Tube voltage 25 to 60 kV, tube current 0.3 to 7.0 mA, output 7.5 to 210 W		Tube voltage 25 to 80 kV, tube current 0.3 to 7.0 mA, output 7.5 to 210 W	
Safety	X-ray leakage maximum 1 μSv/h or less, prevention of x-ray leakage by safety devices			
Display	15-inch color TFT LCD (unified image monitoring screen and operation screen)			
Operation method	Touch panel (with touch buzzer)			
Product size ²	Maximum width 240 mm, maximum height 120 mm (see drawing for detection area)			
Belt width	270 mm			
Masking function	Equipped as standard			
Missing product detection function	Equipped as standard			
Clip check function	Equipped as standard			
Preset memory	Maximum 100			
Belt speed ³	5 to 60 m/min, maximum 5 kg			
Maximum product weight ⁴	61 to 90 m/min, maximum 2 kg			
	5 to 40 m/min, maximum 10 kg (optional)			
Power requirements ^{5, 6, 7}	100 to 120 or 200 to 240 Vac, single phase, 50/60 Hz, 1.0 kVA, rush current 80 A (typ.) (5 ms or less)			
Mass	210 kg	215 kg	220 kg	225 kg
Environmental conditions ⁸	Temperature: 0° to 35°C (0° to 40°C with optional air conditioner), relative humidity: 30% to 85%, non-condensing			
Protection class	Conveyor IP66, other parts IP40, tool free belt removal			
Exterior	Stainless steel (SUS304)			

¹: Actual sensitivity depends on the physical properties of products (contents and shape) and on the environmental conditions. ²: The entrance and exit may require covers depending on the length of a product. ³: Variable depending on Product No. ⁴: Sum total of product weight on the conveyor. ⁵: Selectable by switching terminals. Note that the rush current shown above is at an AC voltage of 200 V. It varies according to voltage. ⁶: Allowable power fluctuation range is ± 10%. ⁷: Installing the air-conditioner option changes the displayed power consumption. ⁸: The air-conditioner option may be required depending on the operating environment. Note: The noise level of x-ray inspection systems is 77 dB(A).

KD74 series
 KD74-h series
 KD74-f series
 DualX
 For Specific Applications

Standard

KD74 series

For Packaged Products

KD7416AWH/ADWH/BWH/BDWH

Maximum width Maximum height
Product size: 390 mm × 150 mm

KD7417BWH

Maximum width Maximum height
Product size: 390 mm × 220 mm



KD7416AWH

External Dimensions

KD7416AWH KD7416ADWH *
KD7416BWH KD7416BDWH *

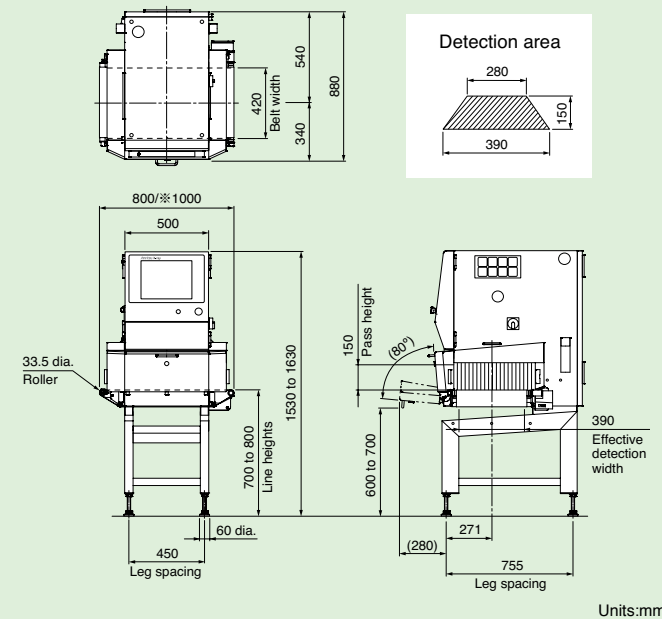

Units:mm

KD7417BWH

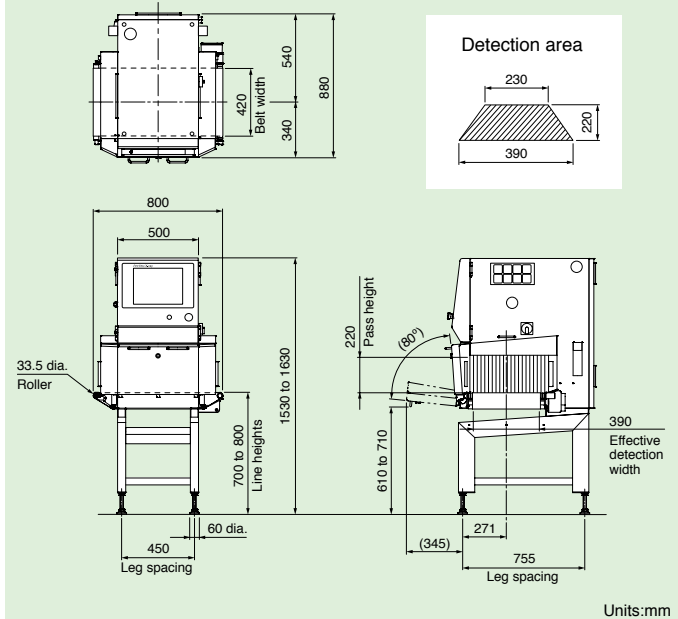

Units:mm

Specifications

Model	KD7416AWH	KD7416ADWH	KD7416BWH	KD7416BDWH	KD7417BWH
Detection sensitivity ¹	Fe sphere and SUS sphere 0.3 mm dia., SUS wire 0.2 mm dia.x 2 mm long				
X-ray output	Tube voltage 25 to 60 kV, tube current 0.3 to 7.0 mA, output 7.5 to 210 W		Tube voltage 25 to 80 kV, tube current 0.3 to 7.0 mA, output 7.5 to 210 W		
Safety	X-ray leakage maximum 1 μSv/h or less, prevention of x-ray leakage by safety devices				
Display	15-inch color TFT LCD (unified image monitoring screen and operation screen)				
Operation method	Touch panel (with touch buzzer)				
Product size ^{2,3}	Maximum width 390 mm, maximum height 150 mm				Maximum width 390 mm, maximum height 220 mm
Belt width	420 mm				
Masking function	Equipped as standard				
Missing product detection function	Equipped as standard				
Clip check function	Equipped as standard				
Preset memory	Maximum 100				
Belt speed ⁴	5 to 60 m/min, maximum 5 kg				5 to 40 m/min, maximum 10 kg
Maximum product weight ⁵	5 to 40 m/min, maximum 10 kg (optional)				—
Power requirements ^{6,7,8}	100 to 120 or 200 to 240 Vac, single phase, 50/60 Hz, 1.0 kVA, rush current 80 A (typ.) (5 ms or less)				
Mass	255 kg	260 kg	265 kg	270 kg	265 kg
Environmental conditions ⁹	Temperature: 0° to 35°C (0° to 40°C with optional air conditioner), relative humidity: 30% to 85%, non-condensing				
Protection class	Conveyor IP66, other parts IP40, tool free belt removal				
Exterior	Stainless steel (SUS304)				

1: Actual sensitivity depends on the physical properties of products (contents and shape) and on the environmental conditions. 2: The detection area is shown above. 3: The entrance and exit may require covers depending on the length of a product. 4: Variable depending on Product No. 5: Sum total of product weight on the conveyor. 6: Selectable by switching terminals. Note that the rush current shown above is at an AC voltage of 200 V. It varies according to voltage. 7: Allowable power fluctuation range is ± 10%. 8: Installing the air-conditioner option changes the displayed power consumption. 9: The air-conditioner option may be required depending on the operating environment. Note: The noise level of x-ray inspection systems is 77 dB(A).

Standard

KD74 series

For Bulk Flow of Unpacked Fresh Food

KD7405ABWH

Maximum width Maximum height
Product size: 240 mm × 50 mm

KD7416ABWH

Maximum width Maximum height
Product size: 390 mm × 50 mm



KD7405ABWH

External Dimensions

KD7405ABWH
KD7416ABWH *

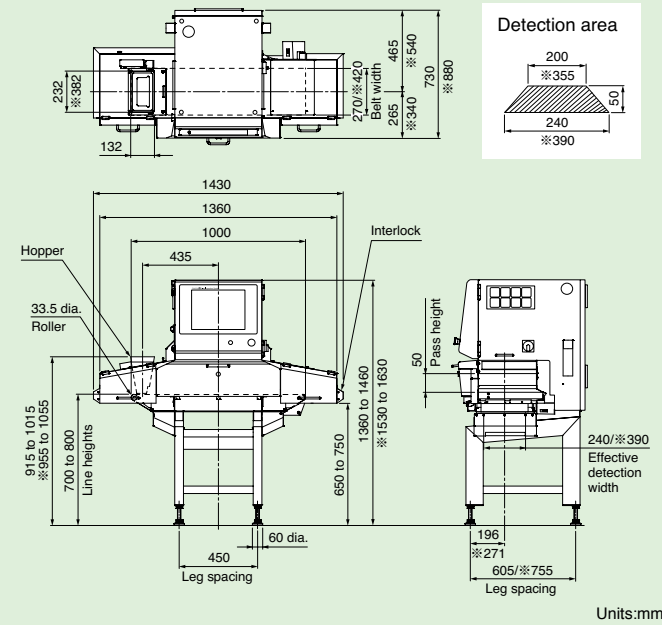

A shield plate and a x-ray leakage prevention cover prevent x-ray leakage.

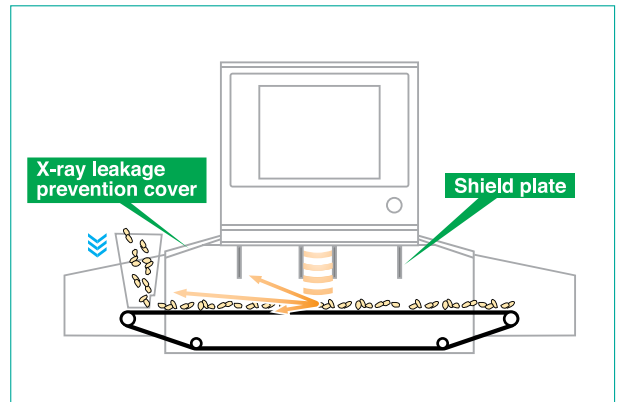

Specifications

Model	KD7405ABWH	KD7416ABWH
Detection sensitivity ¹	Fe sphere and SUS sphere 0.3 mm dia., SUS wire 0.2 mm dia.x 2 mm long	
X-ray output	Tube voltage 25 to 60 kV, tube current 0.3 to 7.0 mA, output 7.5 to 210 W	
Safety	X-ray leakage maximum 1 μSv/h or less, prevention of x-ray leakage by safety devices	
Display	15-inch color TFT LCD (unified image monitoring screen and operation screen)	
Operation method	Touch panel (with touch buzzer)	
Product size ^{2,3}	Maximum width 240 mm, maximum height 50 mm	Maximum width 390 mm, maximum height 50 mm
Belt width	270 mm	420 mm
Masking function	Equipped as standard	
Missing product detection function	Equipped as standard	
Clip check function	Equipped as standard	
Preset memory	Maximum 100	
Belt speed ⁴	5 to 50 m/min, maximum 5 kg	
Maximum product weight ⁵	5 to 40 m/min, maximum 10 kg (optional)	
Power requirements ^{6,7,8}	100 to 120 or 200 to 240 Vac, single phase, 50/60 Hz, 1.0 kVA, rush current 80 A (typ.) (5 ms or less)	
Mass	230 kg	280 kg
Environmental conditions ⁹	Temperature: 0° to 35°C (0° to 40°C with optional air conditioner), relative humidity: 30% to 85%, non-condensing	
Protection class	Conveyor IP66, other parts IP40, tool free belt removal	
Exterior	Stainless steel (SUS304)	

1: Actual sensitivity depends on the physical properties of products (contents and shape) and on the environmental conditions. 2: The detection area is shown above. 3: The entrance and exit may require covers depending on the length of a product. 4: Variable depending on Product No. 5: Sum total of product weight on the conveyor. 6: Selectable by switching terminals. Note that the rush current shown above is at an AC voltage of 200 V. It varies according to voltage. 7: Allowable power fluctuation range is ± 10%. 8: Installing the air-conditioner option changes the displayed power consumption. 9: The air-conditioner option may be required depending on the operating environment. Note: The noise level of x-ray inspection systems is 77 dB(A).

Standard

KD74 series

For Lightweight Products and Those in Small Bags

KD7405ACWH

Maximum width Maximum height
Product size: 240 mm × 50 mm

KD7416ACWH

Maximum width Maximum height
Product size: 390 mm × 50 mm



KD7405ACWH

External Dimensions

KD7405ACWH
KD7416ACWH *

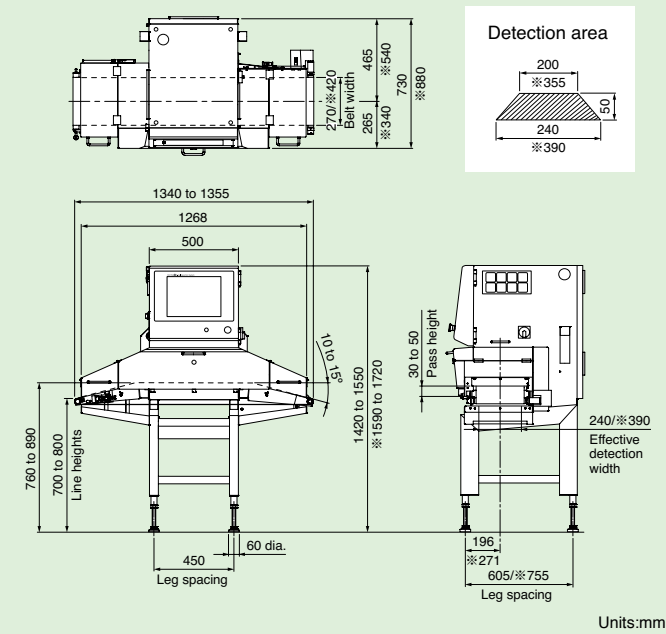

Instead of x-ray protection curtains that could disrupt product flow, an inclined conveyor with covers is equipped for stable conveyance.

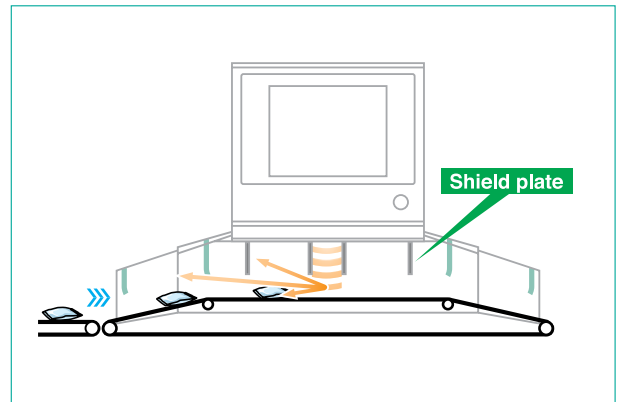

Specifications

Model	KD7405ACWH	KD7416ACWH
Detection sensitivity ¹	Fe sphere and SUS sphere 0.3 mm dia., SUS wire 0.2 mm dia.x 2 mm long	
X-ray output	Tube voltage 25 to 60 kV, tube current 0.3 to 7.0 mA, output 7.5 to 210 W	
Safety	X-ray leakage maximum 1 μSv/h or less, prevention of x-ray leakage by safety devices	
Display	15-inch color TFT LCD (unified image monitoring screen and operation screen)	
Operation method	Touch panel (with touch buzzer)	
Product size ^{2,3}	Maximum width 240 mm, maximum height 50 mm	Maximum width 390 mm, maximum height 50 mm
Belt width	270 mm	420 mm
Masking function	Equipped as standard	
Missing product detection function	Equipped as standard	
Clip check function	Equipped as standard	
Preset memory	Maximum 100	
Belt speed ⁴	5 to 50 m/min, maximum 5 kg	
Maximum product weight ⁵	5 to 40 m/min, maximum 10 kg (optional)	
Power requirements ^{6,7,8}	100 to 120 or 200 to 240 Vac, single phase, 50/60 Hz, 1.0 kVA, rush current 80 A (typ.) (5 ms or less)	
Mass	230 kg	285 kg
Environmental conditions ⁹	Temperature: 0° to 35°C (0° to 40°C with optional air conditioner), relative humidity: 30% to 85%, non-condensing	
Protection class	Conveyor IP66, other parts IP40, tool free belt removal	
Exterior	Stainless steel (SUS304)	

1: Actual sensitivity depends on the physical properties of products (contents and shape) and on the environmental conditions. 2: The detection area is shown above. 3: The entrance and exit may require covers depending on the length of a product. 4: Variable depending on Product No. 5: Sum total of product weight on the conveyor. 6: Selectable by switching terminals. Note that the rush current shown above is at an AC voltage of 200 V. It varies according to voltage. 7: Allowable power fluctuation range is ± 10%. 8: Installing the air-conditioner option changes the displayed power consumption. 9: The air-conditioner option may be required depending on the operating environment. Note: The noise level of x-ray inspection systems is 77 dB(A).

High Definition

KD74-h series

For Packaged Products

KD7405CWT/DWT

Maximum width Maximum height
Product size: 240 mm × 120 mm



KD7405DWT

External Dimensions

KD7405CWT
KD7405DWT

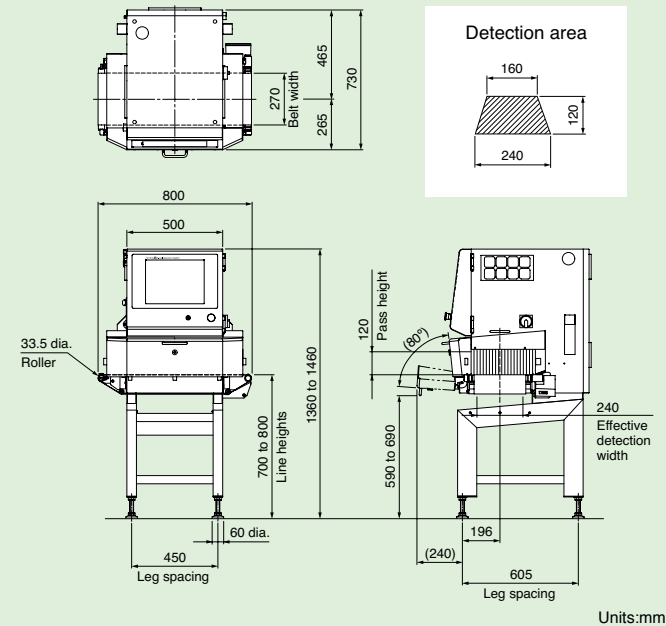

Specifications

Model	KD7405CWT	KD7405DWT
Detection sensitivity ¹	Fe sphere and SUS sphere 0.2 mm dia. ² , SUS wire 0.2 mm dia.x 2 mm long	
X-ray output	Tube voltage 25 to 60 kV, tube current 0.3 to 7.0 mA, output 7.5 to 300 W	Tube voltage 25 to 80 kV, tube current 0.3 to 10.0 mA, output 7.5 to 350 W
Safety	X-ray leakage maximum 1 μSv/h or less, prevention of x-ray leakage by safety devices	
Display	15-inch color TFT LCD (unified image monitoring screen and operation screen)	
Operation method	Touch panel (with touch buzzer)	
Product size ³	Maximum width 240 mm, maximum height 120 mm (see drawing for detection area)	
Belt width	270 mm	
Masking function	Equipped as standard	
Missing product detection function	Equipped as standard	
Clip check function	Equipped as standard	
Preset memory	Maximum 100	
Belt speed ⁴	10 to 60 m/min, maximum 5 kg	
Maximum product weight ⁵	61 to 90 m/min, maximum 2 kg 5 to 40 m/min, maximum 10 kg (optional)	
Power requirements ^{6, 7, 8}	100 to 120 or 200 to 240 Vac, single phase, 50/60 Hz, 1.0 kVA, rush current 80 A (typ.) (5 ms or less)	
Mass	230 kg	
Environmental conditions ⁹	Temperature: 0° to 35°C (0° to 40°C with optional air conditioner), relative humidity: 30% to 85%, non-condensing	
Protection class	Conveyor IP66, other parts IP40, tool free belt removal	
Exterior	Stainless steel (SUS304)	

1: Actual sensitivity depends on the physical properties of products (contents and shape) and on the environmental conditions. 2: Reference value using Anritsu test piece. 3: The entrance and exit may require covers depending on the length of a product. 4: Variable depending on Product No. 5: Sum total of product weight on the conveyor. 6: Selectable by switching terminals. Note that the rush current shown above is at an AC voltage of 200 V. It varies according to voltage. 7: Allowable power fluctuation range is ± 10%. 8: Installing the air-conditioner option changes the displayed power consumption. 9: The air-conditioner option may be required depending on the operating environment. Note: The noise level of x-ray inspection systems is 77 dB(A).

KD74 series

KD74-h series

KD74-f series

DualX

For Specific Applications

High Definition

KD74-h series

For Packaged Products

KD7405DWH

Maximum width Maximum height
Product size: 240 mm × 120 mm

KD7416DWH

Maximum width Maximum height
Product size: 390 mm × 150 mm

KD7417DWH

Maximum width Maximum height
Product size: 390 mm × 220 mm



KD7416DWH

External Dimensions

KD7405DWH

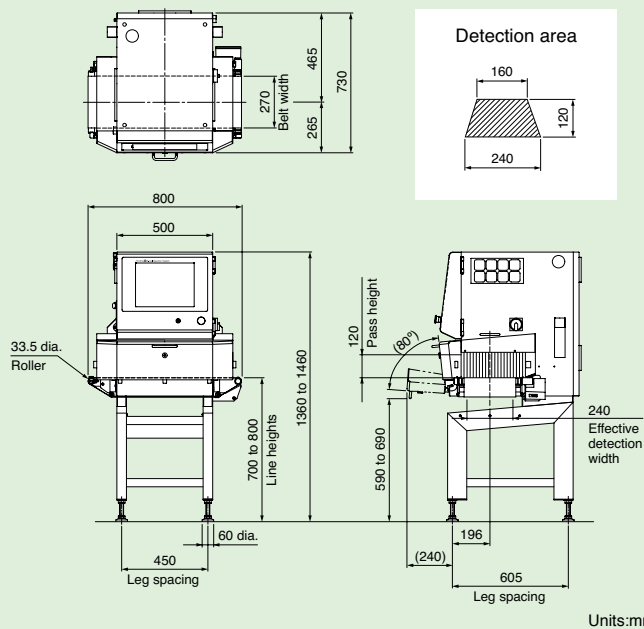

KD7416DWH KD7417DWH *

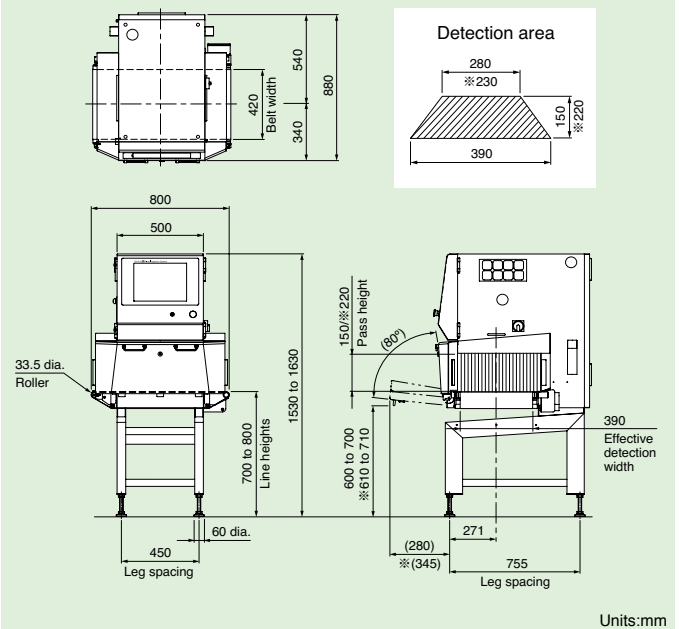

Specifications

Model	KD7405DWH	KD7416DWH	KD7417DWH
Detection sensitivity ¹	Fe sphere and SUS sphere 0.3 mm dia., SUS wire 0.2 mm dia. x 2 mm long		
X-ray output	Tube voltage 25 to 80 kV, tube current 0.3 to 10.0 mA, output 7.5 to 350 W		
Safety	X-ray leakage maximum 1 μ Sv/h or less, prevention of x-ray leakage by safety devices		
Display	15-inch color TFT LCD (unified image monitoring screen and operation screen)		
Operation method	Touch panel (with touch buzzer)		
Product size ^{2,3}	Maximum width 240 mm, maximum height 120 mm	Maximum width 390 mm, maximum height 150 mm	Maximum width 390 mm, maximum height 220 mm
Belt width	270 mm	420 mm	
Masking function	Equipped as standard		
Missing product detection function	Equipped as standard		
Clip check function	Equipped as standard		
Preset memory	Maximum 100		
Belt speed ⁴	10 to 60 m/min, maximum 5 kg	5 to 60 m/min, maximum 5 kg	5 to 40 m/min, maximum 10 kg
Maximum product weight ⁵	61 to 90 m/min, maximum 2 kg	5 to 40 m/min, maximum 10 kg (optional)	—
	5 to 40 m/min, maximum 10 kg (optional)	—	—
Power requirements ^{6,7,8}	100 to 120 or 200 to 240 Vac, single phase, 50/60 Hz, 1.0 kVA, rush current 80 A (typ.) (5 ms or less)		
Mass	230 kg	280 kg	
Environmental conditions ⁹	Temperature: 0° to 35°C (0° to 40°C with optional air conditioner), relative humidity: 30% to 85%, non-condensing		
Protection class	Conveyor IP66, other parts IP40, tool free belt removal		
Exterior	Stainless steel (SUS304)		

¹: Actual sensitivity depends on the physical properties of products (contents and shape) and on the environmental conditions. ²: The detection area is shown above. ³: The entrance and exit may require covers depending on the length of a product. ⁴: Variable depending on Product No. ⁵: Sum total of product weight on the conveyor. ⁶: Selectable by switching terminals. Note that the rush current shown above is at an AC voltage of 200 V. It varies according to voltage. ⁷: Allowable power fluctuation range is $\pm 10\%$. ⁸: Installing the air-conditioner option changes the displayed power consumption. ⁹: The air-conditioner option may be required depending on the operating environment. Note: The noise level of x-ray inspection systems is 77 dB(A).

Entry

KD74-f series

For Packaged Products

KD7405KP/KDP

Maximum width Maximum height
Product size: 240 mm × 120 mm

For Lightweight Products and Those in Small Bags

KD7405KCP

Maximum width Maximum height
Product size: 240 mm × 50 mm



KD7405KP

External Dimensions

KD7405KP
KD7405KDP *

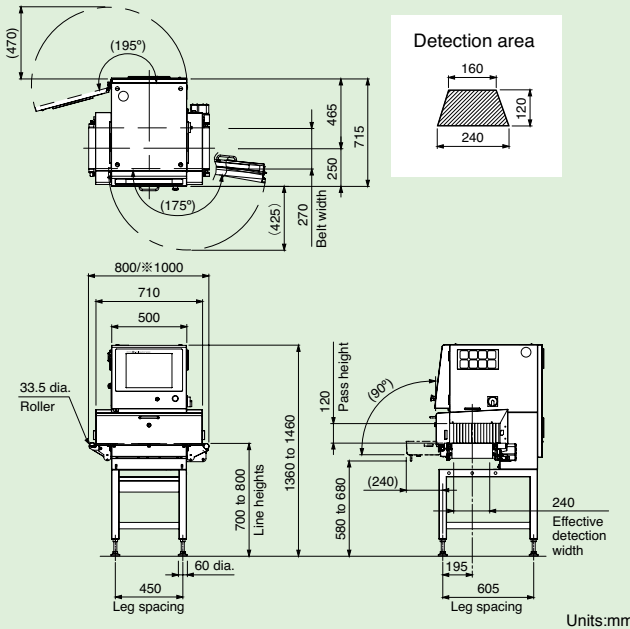

Units:mm

KD7405KCP

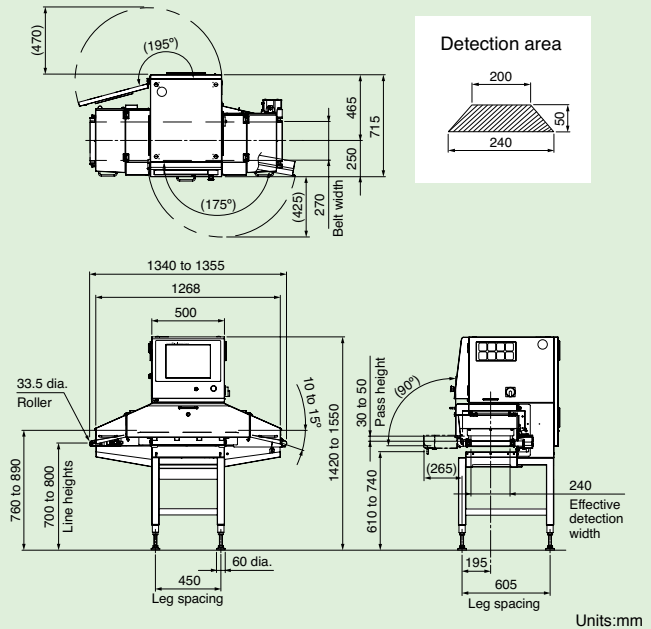

Units:mm

Specifications

Model	KD7405KP	KD7405KDP	KD7405KCP
Detection sensitivity ¹	Fe sphere and SUS sphere 0.3 mm dia., SUS wire 0.2 mm dia. x 2 mm long		
X-ray output	Tube voltage 25 to 50 kV, tube current 0.3 to 4.0 mA, output 7.5 to 100 W		
Safety	X-ray leakage maximum 1 μSv/h or less, prevention of x-ray leakage by safety devices		
Display	15-inch color TFT LCD (unified image monitoring screen and operation screen)		
Operation method	Touch panel (with touch buzzer)		
Product size ^{2,3}	Maximum width 240 mm, maximum height 120 mm		Maximum width 240 mm, maximum height 50 mm
Belt width	270 mm		
Masking function	Equipped as standard		
Missing product detection function	Equipped as standard		
Clip check function	Equipped as standard		
Preset memory	Maximum 100		
Belt speed ⁴	5 to 60 m/min, maximum 3 kg		5 to 50 m/min, maximum 3 kg
Maximum product weight ⁵	61 to 80 m/min, maximum 2 kg		5 to 35 m/min, maximum 6 kg (optional)
	5 to 35 m/min, maximum 6 kg (optional)		—
Power requirements ^{6,7,8}	100 to 120 or 200 to 240 Vac, single phase, 50/60 Hz, 700 VA, rush current 80 A (typ.) (5 ms or less)		
Mass	200 kg	205 kg	220 kg
Environmental conditions ⁹	Temperature: 0° to 35°C (0° to 40°C with optional air conditioner), relative humidity: 30% to 85%, non-condensing		
Protection class	Conveyor IP40, tool free belt removal		
Exterior	Stainless steel (SUS304)		

¹: Actual sensitivity depends on the physical properties of products (contents and shape) and on the environmental conditions. ²: The detection area is shown above. ³: The entrance and exit may require covers depending on the length of a product. ⁴: Variable depending on Product No. ⁵: Sum total of product weight on the conveyor. ⁶: Selectable by switching terminals. Note that the rush current shown above is at an AC voltage of 200 V. It varies according to voltage. ⁷: Allowable power fluctuation range is ± 10%. ⁸: Installing the air-conditioner option changes the displayed power consumption. ⁹: The air-conditioner option may be required depending on the operating environment. Note: The noise level of x-ray inspection systems is 72 dB(A).

DualX

KD74 series DUAL ENERGY

For Packaged Products

KD7416AWZE/ADWZE

Maximum width Maximum height
Product size: 390 mm × 150 mm

For Lightweight Products and Those in Small Bags

KD7416ACWZE

Maximum width Maximum height
Product size: 390 mm × 50 mm



KD7416AWZE

External Dimensions

KD7416AWZE
KD7416ADWZE *

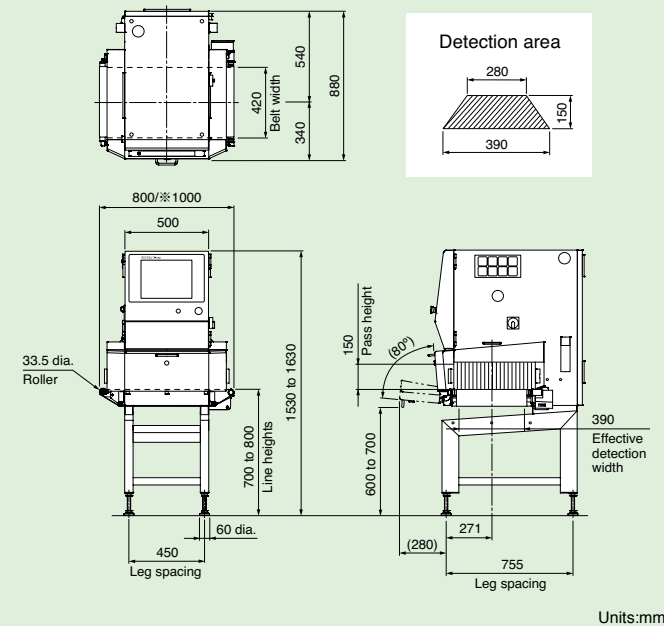

KD7416ACWZE

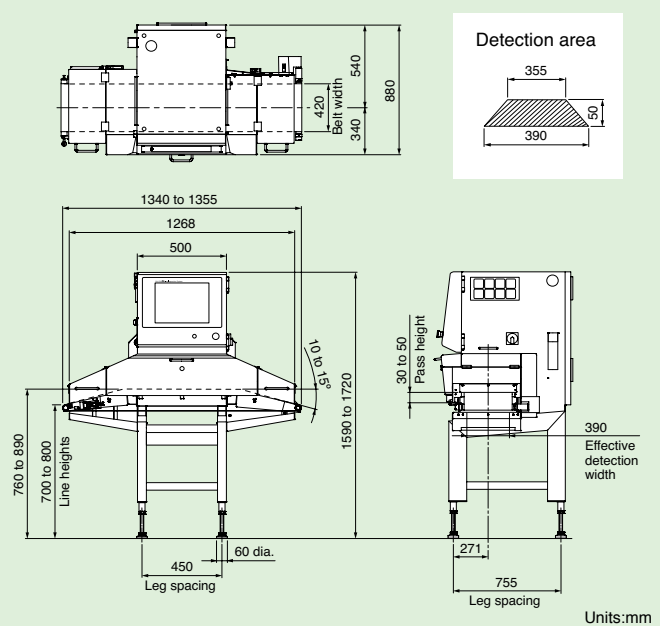

Specifications

Model	KD7416AWZE	KD7416ADWZE	KD7416ACWZE
X-ray output	Tube voltage 25 to 60 kV, tube current 0.3 to 7.0 mA, output 7.5 to 210 W		
Safety	X-ray leakage maximum 1 μSv/h or less, prevention of x-ray leakage by safety devices		
Display	15-inch color TFT LCD (unified image monitoring screen and operation screen)		
Operation method	Touch panel (with touch buzzer)		
Product size ^{1,2}	Maximum width 390 mm, maximum height 150 mm		Maximum width 390 mm, maximum height 50 mm
Belt width	420 mm		
Masking function	Equipped as standard		
Missing product detection function	Equipped as standard		
Clip check function	Equipped as standard		
Preset memory	Maximum 100		
Belt speed ³	10 to 60 m/min, maximum 5 kg		10 to 50 m/min, maximum 5 kg
Maximum product weight ⁴	10 to 40 m/min, maximum 10 kg (optional)		10 to 40 m/min, maximum 10 kg (optional)
Power requirements ^{5,6,7}	100 to 120 or 200 to 240 Vac, single phase, 50/60 Hz, 1.0 kVA, rush current 80 A (typ.) (5 ms or less)		
Mass	255 kg	260 kg	285 kg
Environmental conditions ⁸	Temperature: 0° to 35°C (0° to 40°C with optional air conditioner), relative humidity: 30% to 85%, non-condensing		
Protection class	Conveyor IP66, other parts IP40, tool free belt removal		
Exterior	Stainless steel (SUS304)		

1: The detection area is shown above. 2: The entrance and exit may require covers depending on the length of a product. 3: Variable depending on Product No. 4: Sum total of product weight on the conveyor. 5: Selectable by switching terminals. Note that the rush current shown above is at an AC voltage of 200 V. It varies according to voltage. 6: Allowable power fluctuation range is ± 10%. 7: Installing the air-conditioner option changes the displayed power consumption. 8: The air-conditioner option may be required depending on the operating environment. Note: The noise level of x-ray inspection systems does not exceed 70 dB(A).

KD74 series

KD74-h series

KD74-f series

DualX

For Specific Applications

DualX

KD74 series  DUAL ENERGY

For Packaged Products

KD7416DWZ

Maximum width Maximum height
 Product size: 390 mm × 150 mm



KD7416DWZ

External Dimensions

KD7416DWZ

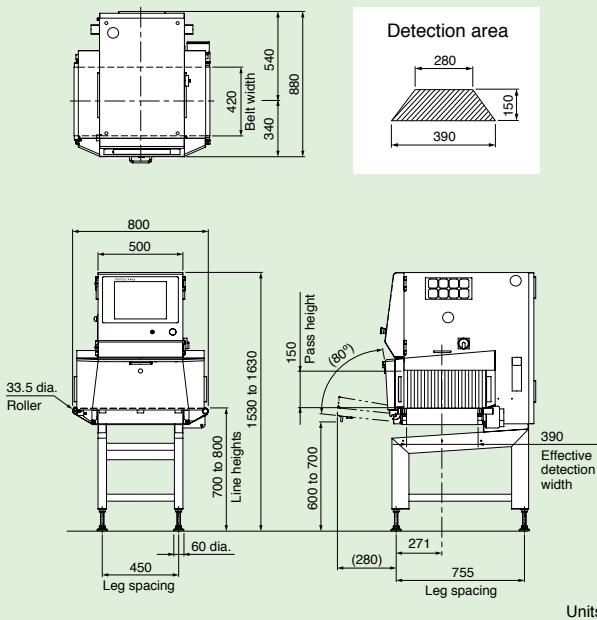

Specifications

Model	KD7416DWZ
X-ray output	Tube voltage 25 to 80 kV, tube current 0.4 to 10.0 mA, output 10 to 350 W
Safety	X-ray leakage maximum 1 μ Sv/h or less, prevention of x-ray leakage by safety devices
Safety	15-inch color TFT LCD (unified image monitoring screen and operation screen)
Display	Touch panel (with touch buzzer)
Product size ¹	Maximum width 390 mm, maximum height 150 mm (see drawing for detection area)
Belt width	420 mm
Masking function	Equipped as standard
Missing product detection function	Equipped as standard
Clip check function	Equipped as standard
Preset memory	Maximum 100
Belt speed ²	5 to 60 m/min, maximum 5 kg
Maximum product weight ³	5 to 40 m/min, maximum 10 kg (optional)
Power requirements ^{4, 5, 6}	100 to 120 or 200 to 240 Vac, single phase, 50/60 Hz, 1.0 kVA, rush current 80 A (typ.) (5 ms or less)
Mass	280 kg
Environmental conditions ⁷	Temperature: 0° to 35°C (0° to 40°C with optional air conditioner), relative humidity: 30% to 85%, non-condensing
Protection class	Conveyor IP66, other parts IP40, tool free belt removal
Exterior	Stainless steel (SUS304)

1: The entrance and exit may require covers depending on the length of a product. 2: Variable depending on Product No. 3: Sum total of product weight on the conveyor. 4: Selectable by switching terminals. Note that the rush current shown above is at an AC voltage of 200 V. It varies according to voltage. 5: Allowable power fluctuation range is $\pm 10\%$. 6: Installing the air-conditioner option changes the displayed power consumption. 7: The air-conditioner option may be required depending on the operating environment. Note: The noise level of x-ray inspection systems is 77 dB(A).

For Specific Applications

Large Products and Cartons

KD74 series

For Packaged Products

KD7447DW/DWE/FWE

Maximum width Maximum height
Product size: 590 mm × 250 mm



KD7447DW

External Dimensions

KD7447DW
KD7447DWE

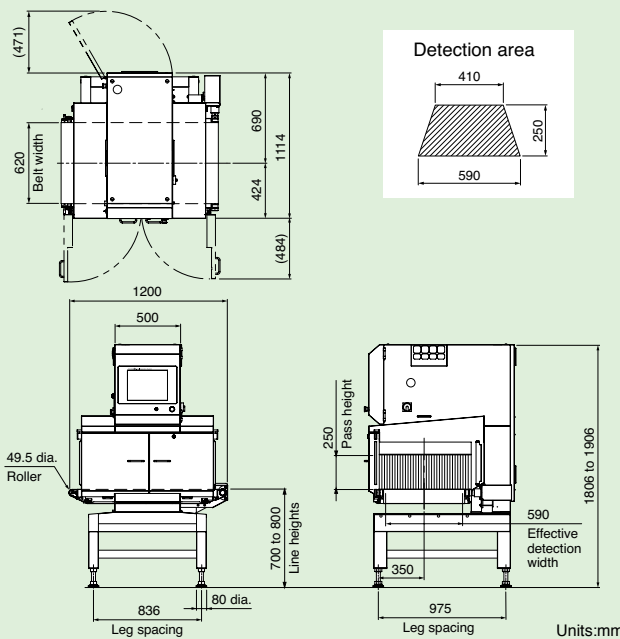

KD7447FWE

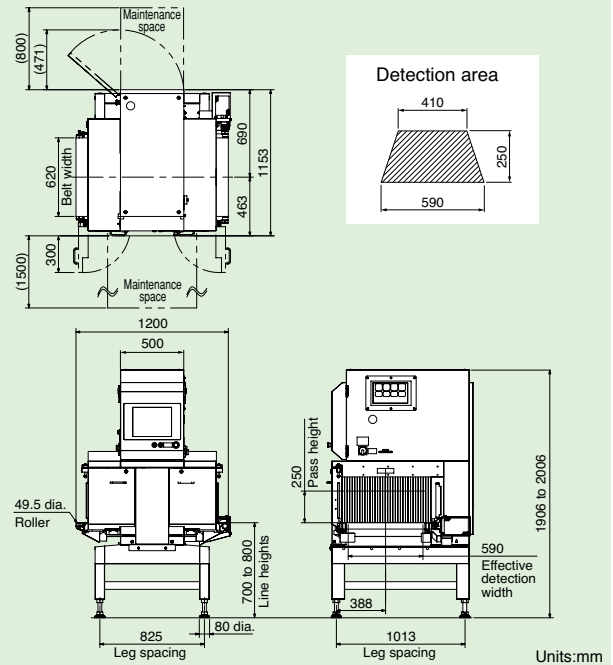

Specifications

Model	KD7447DW	KD7447DWE	KD7447FWE
Detection sensitivity ¹	Fe sphere and SUS sphere 0.4 mm dia.	Fe sphere and SUS sphere 0.5 mm dia.	Fe sphere and SUS sphere 0.8 mm dia.
X-ray output	Tube voltage 25 to 80 kV, tube current 0.3 to 10.0 mA, output 7.5 to 350 W		Tube voltage 80 to 100 kV, tube current 0.5 to 4.3 mA, output 40 to 350 W
Safety	X-ray leakage maximum 1 μSv/h or less, prevention of x-ray leakage by safety devices		
Display	15-inch color TFT LCD (unified image monitoring screen and operation screen)		
Operation method	Touch panel (with touch buzzer)		
Product size ^{2,3}	Maximum width 590 mm, maximum height 250 mm (see drawing for detection area)		
Belt width	620 mm		
Masking function	Equipped as standard		
Missing product detection function	Equipped as standard		
Clip check function	Equipped as standard		
Preset memory	Maximum 100		
Belt speed ⁴	10 to 35 m/min, maximum 50 kg		10 to 35 m/min, maximum 50 kg ⁷
Maximum product weight ⁵	36 to 40 m/min, maximum 30 kg ⁶		36 to 40 m/min, maximum 30 kg ⁷
	25 to 50 m/min, maximum 20 kg (optional)		25 to 50 m/min, maximum 20 kg (optional) ⁷
Power requirements ^{8,9,10}	100 to 120 or 200 to 240 Vac, single phase, 50/60 Hz, 1.0 kVA, rush current 80 A (typ.) (5 ms or less)		200 to 240 Vac, single phase, 50/60 Hz, 1.0 kVA, rush current 80 A (typ.) (5 ms or less)
Mass	450 kg		650 kg
Environmental conditions ¹¹	Temperature: 0° to 35°C (0° to 40°C with optional air conditioner), relative humidity: 30% to 85%, non-condensing		
Protection class	Conveyor IP66, other parts IP40, tool free belt removal		
Exterior	Stainless steel (SUS304)		

1: Actual sensitivity depends on the physical properties of products (contents and shape) and on the environmental conditions. 2: The entrance and exit may require covers depending on the length of a product. 3: Pass height of 350 mm is available as an option. 4: Variable depending on Product No. 5: Sum total of product weight on the conveyor. 6: In an environment where water or oil regularly splashes the equipment, the maximum is 20 kg. 7: Can decrease if the conveyor is exposed to water or oil. 8: Allowable power fluctuation range is ± 10%. 9: Selectable by switching terminals. Note that the rush current shown above is at an AC voltage of 200 V. It varies according to voltage. 10: Installing the air-conditioner option changes the displayed power consumption. 11: The air-conditioner option may be required depending on the operating environment. Note: The noise level of KD7447DW/KD7447DWE does not exceed 70 dB(A). The noise level of KD7447FWE is 72 dB(A).

For Specific Applications

Large Products and Cartons

KD73 series 

For Packaged Products

KD7337AWH1/AWH2

Maximum width Maximum height
 Product size: 690 mm × 250 mm



KD7337AWH1

Air conditioner is equipped as standard.

External Dimensions

KD7337AWH1
 KD7337AWH2

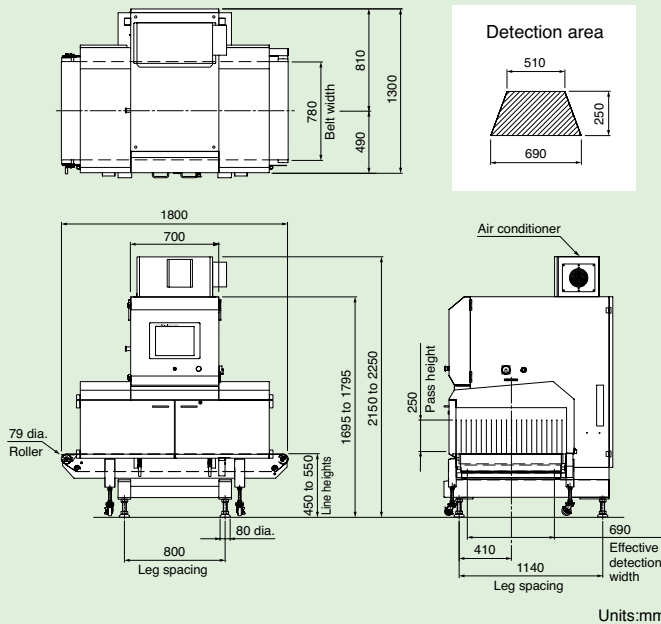

Specifications

Model	KD7337AWH1	KD7337AWH2
Detection sensitivity ¹	Fe sphere and SUS sphere 0.5 mm dia.	
X-ray output	Tube voltage 30 to 80 kV, tube current 0.3 to 7.0 mA, output 9.0 to 350 W	
Safety	X-ray leakage maximum 1 μSv/h or less, prevention of x-ray leakage by safety devices	
Display	15-inch color TFT LCD (unified image monitoring screen and operation screen)	
Operation method	Touch panel (with touch buzzer)	
Product size ²	Maximum width 690 mm, maximum height 250 mm (see drawing for detection area)	
Belt width	780 mm	
Masking function	Equipped as standard	
Missing product detection function	Equipped as standard	
Clip check function	Equipped as standard	
Preset memory	Maximum 100	
Belt speed ³	10 to 30 m/min, maximum 50 kg	
Maximum product weight ⁴	31 to 35 m/min, maximum 40 kg	
Power requirements ⁵	200 Vac, single phase, 50/60 Hz, 1.8 kVA, D class grounding	
Mass	750 kg	
Environmental conditions	Temperature: 0° to 35°C, relative humidity: 30% to 85%, non-condensing	
Protection class	Conveyor IP66, other parts IP52	
Exterior	Stainless steel (SUS304)	
Cooling system	Air conditioner (standard equipped)	

¹: Actual sensitivity depends on the physical properties of products (contents and shape) and on the environmental conditions. ²: The entrance and exit may require covers depending on the length of a product. ³: Variable depending on Product No. ⁴: Sum total of product weight on the conveyor. ⁵: Allowable power fluctuation range is ± 10%. Note: The noise level of x-ray inspection systems is 72 dB(A).

For Specific Applications

Sanitary Design

KD74 series **Sp**

IP69K

For Packaged Products

KD7416AM

Maximum width Maximum height
Product size: 365 mm × 150 mm

For Unpackaged Fresh Meat, Poultry and Fish

KD7416ACM

Maximum width Maximum height
Product size: 365 mm × 50 mm



KD7416ACM

Air conditioner is equipped as standard.

KD7416ADM (1000-mm long) and KD7416ABM (Hopper loading system) are also available. Contact our sales representatives for details.

External Dimensions

KD7416AM

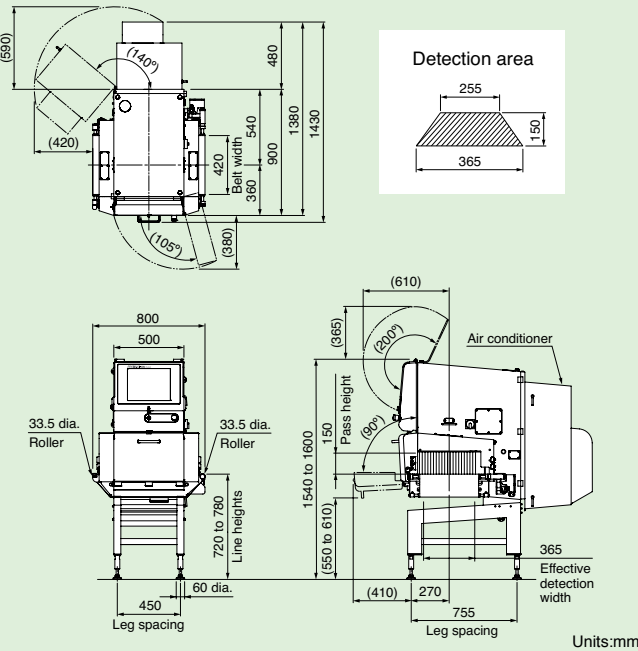

KD7416ACM

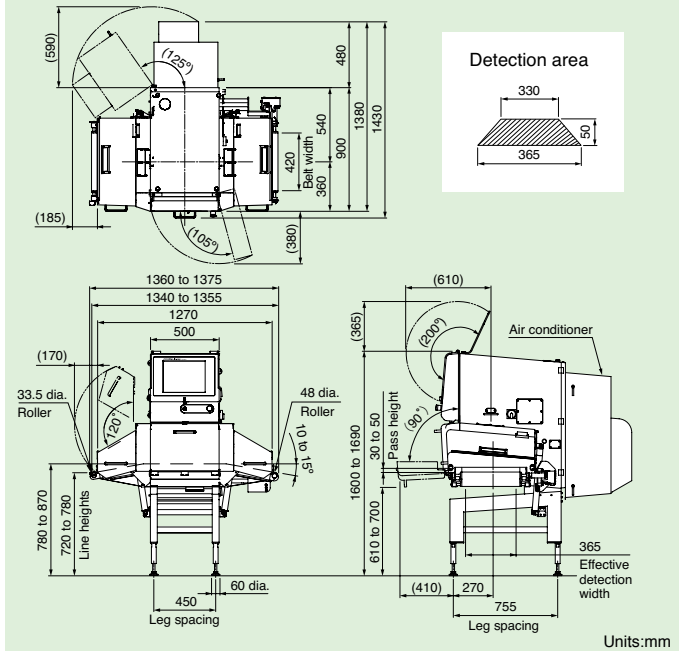

Specifications

Model	KD7416AM	KD7416ACM
Detection sensitivity ¹	Fe sphere and SUS sphere 0.3 mm dia., SUS wire 0.2 mm dia. x 2 mm long	
X-ray output	Tube voltage 25 to 60 kV, tube current 0.3 to 7.0 mA, output 7.5 to 210 W	
Safety	X-ray leakage maximum 1 μSv/h or less, prevention of x-ray leakage by safety devices	
Display	15-inch color TFT LCD (unified image monitoring screen and operation screen)	
Operation method	Touch panel (with touch buzzer)	
Product size ^{2,3}	Maximum width 365 mm, maximum height 150 mm	Maximum width 365 mm, maximum height 50 mm
Belt width	420 mm	
Masking function	Equipped as standard	
Missing product detection function	Equipped as standard	
Clip check function	Equipped as standard	
Preset memory	Maximum 100	
Belt speed ⁴	5 to 40 m/min, maximum 5 kg	5 to 50 m/min, maximum 3 kg
Maximum product weight ⁵	5 to 35 m/min, maximum 10 kg (optional)	5 to 35 m/min, maximum 8 kg (optional)
Power requirements ^{6,7}	100 to 120 or 200 to 240 Vac, single phase, 50/60 Hz, 1.6 kVA, rush current 80 A (typ.) (5 ms or less)	
Mass	335 kg	355 kg
Environmental conditions	Temperature: 0° to 35°C, relative humidity: 30% to 85%, non-condensing	
Protection class ⁸	IP69K (with all protection covers closed)	
Exterior	Stainless steel (SUS304)	
Cooling system	Air conditioner (standard equipped)	

¹: Actual sensitivity depends on the physical properties of products (contents and shape) and on the environmental conditions. ²: The detection area is shown above. ³: The entrance and exit may require covers depending on the length of a product. ⁴: Variable depending on Product No. ⁵: Sum total of product weight on the conveyor. ⁶: Selectable by switching terminals. Note that the rush current shown above is at an AC voltage of 200 V. It varies according to voltage. ⁷: Allowable power fluctuation range is ± 10%. ⁸: Excluding air-conditioner ventilation hole. Note: The noise level of x-ray inspection systems is 82 dB(A).

For Specific Applications

Tall Products

KD74 series

For Packaged Products

KD7478AWH/BWH

Maximum width Maximum height
Product size: 120 mm × 350 mm

Note: Not usable for glass containers.



KD7478AWH

External Dimensions

KD7478AWH
KD7478BWH

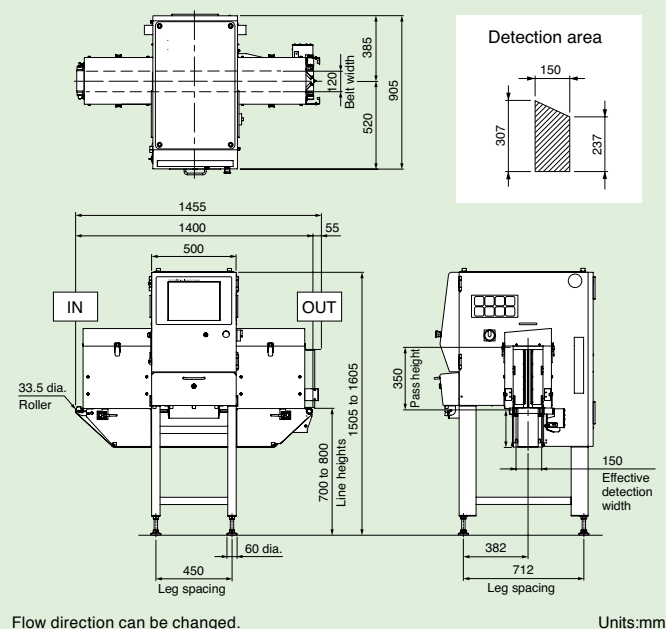

Specifications

Model	KD7478AWH	KD7478BWH
Detection sensitivity ¹	Fe sphere and SUS sphere 0.4 mm dia.	
X-ray output	Tube voltage 25 to 60 kV, tube current 0.3 to 7.0 mA, output 7.5 to 210 W	Tube voltage 25 to 80 kV, tube current 0.3 to 7.0 mA, output 7.5 to 210 W
Safety	X-ray leakage maximum 1 μSv/h or less, prevention of x-ray leakage by safety devices	
Display	15-inch color TFT LCD (unified image monitoring screen and operation screen)	
Operation method	Touch panel (with touch buzzer)	
Product size ²	Maximum width 120 mm, maximum height 350 mm (see drawing for detection area)	
Belt width	120 mm	
Masking function	Equipped as standard	
Missing product detection function	Equipped as standard	
Clip check function	Equipped as standard	
Preset memory	Maximum 100	
Belt speed ³	5 to 60 m/min, maximum 5 kg	
Maximum product weight ⁴	5 to 60 m/min, maximum 5 kg	
Power requirements ^{5, 6, 7}	100 to 120 or 200 to 240 Vac, single phase, 50/60 Hz, 1.0 kVA, rush current 80 A (typ.) (5 ms or less)	
Mass	310 kg	315 kg
Environmental conditions ⁸	Temperature: 0° to 35°C (0° to 40°C with optional air conditioner), relative humidity: 30% to 85%, non-condensing	
Protection class	Conveyor IP66, other parts IP40, tool free belt removal	
Exterior	Stainless steel (SUS304)	

1: Actual sensitivity depends on the physical properties of products (contents and shape) and on the environmental conditions. 2: The entrance and exit may require covers depending on the length of a product. 3: Variable depending on Product No. 4: Sum total of product weight on the conveyor. 5: Selectable by switching terminals. Note that the rush current shown above is at an AC voltage of 200 V. It varies according to voltage. 6: Allowable power fluctuation range is ± 10%. 7: Installing the air-conditioner option changes the displayed power consumption. 8: The air-conditioner option may be required depending on the operating environment. Note: The noise level of x-ray inspection systems does not exceed 70 dB(A).

For Specific Applications Pipe type

KD74 series Sp

For Pumped Products

KD7483AFWH

Solids in fluid

Product size: 12 mm

(Less than 1/3 of the minimum height of the inspection section)



KD7483AFWH

Air conditioner is equipped as standard.

External Dimensions

KD7483AFWH

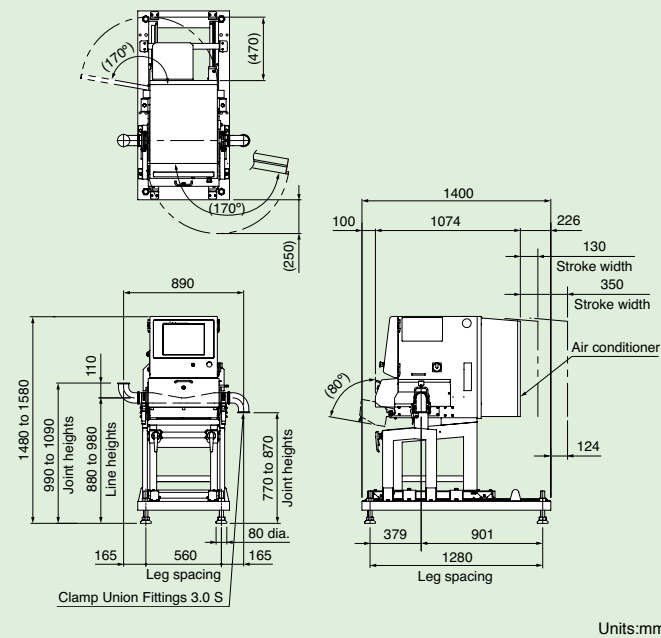

Specifications

Model	KD7483AFWH
Detection sensitivity ¹	Fe sphere and SUS sphere 0.6 mm dia. (when only water is conveyed)
X-ray output	Tube voltage 25 to 60 kV, tube current 0.3 to 7.0 mA, output 7.5 to 210 W
Safety	X-ray leakage maximum 1 μ Sv/h or less, prevention of x-ray leakage by safety devices
Display	15-inch color TFT LCD (unified image monitoring screen and operation screen)
Operation method	Touch panel (with touch buzzer)
Product size Product: solids in fluid	12 mm or smaller (less than 1/3 of the minimum height of the inspection section)
Transfer pipe dimension	3-inch (76.2 mm) dia.
Inspection section pass height	35 mm (fixed)
Position change at sensitivity adjustment	Main unit position change (pipe position fixed)
Preset memory	Maximum 100
Processing capacity (flow)	11.0 kL/h
Power requirements ^{2,3}	100 to 120 or 200 to 240 Vac, single phase, 50/60 Hz, 1.6 kVA, rush current 80 A (typ.) (5 ms or less)
Mass	340 kg
Environmental conditions	Temperature: 0° to 40°C, relative humidity: 30% to 85%, non-condensing
Protection class	Product transfer pipe IP66, other parts IP40
Exterior	Stainless steel (SUS304)
Cooling system	Air conditioner (standard equipped)

1: Actual sensitivity depends on the physical properties of products (contents and shape) and on the environmental conditions. 2: Allowable power fluctuation range is $\pm 10\%$. 3: Selectable by switching terminals. Note that the rush current shown above is at an AC voltage of 200 V. It varies according to voltage. Note: The noise level of x-ray inspection systems is 71 dB(A).

Safety in design

Anritsu believes customer safety is of utmost importance.

Anritsu safety mechanism

Emergency stop switch

Cuts power to x-ray and drive circuits, stops the conveyor and x-ray radiation.

X-ray ON/OFF key

Turning the key to OFF stops x-ray radiation completely.

X-ray shield cover open/close sensor

Opening the cover stops x-ray radiation.

X-ray shield cover

Opened/Closed using x-ray Irradiation ON/OFF Key.
Opening the cover stops x-ray radiation due to the x-ray Shield Cover Open/Close Sensor.

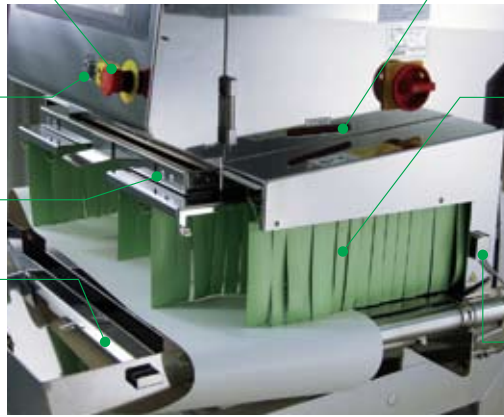

X-ray irradiation display

The lamp is lit during x-ray radiation.

Leakage prevention curtain

Prevents x-ray leakage. For unpackaged or bulk products, the standard lead impregnated curtains are replaced with SUS plates and covers – preventing direct food contact with the curtains.

Hand insertion sensor

Interrupting the sensor for a certain period of time stops x-ray radiation.

Safety management

X-ray Inspection System has been designed to fully satisfy the safe operation. However, to ensure even higher safety, use the safety procedures outlined below.

- ① **Periodic measurement and recording of x-ray leakage data**
- ② **Management of operator working hours**
- ③ **Additional safety measures**
Covers may need to be mounted on upstream and downstream conveyors instead of the shield curtains, depending on the shape, weight, and package of products.
- ④ **No disassembly or modification**
NEVER modify or disassemble the main unit, covers, x-ray leakage prevention curtains, safety covers, safety interlocks, etc., otherwise the x-ray leak-proof design may no longer be functional.

Safety of inspected products

WHO concluded in 1980 that the “irradiation of any food commodity up to an overall average dose of 10 kGy presents no toxicological hazard and introduces no special nutritional or microbiological problems.”

The maximum dose of x-ray irradiation to the products to be inspected by our x-ray inspection systems is 0.002 Gy, which is much lower than the value described above. Even if a product stops inside, the x-ray dose is always kept to 0.1 Gy or less.

Note: Follow the local laws and regulations regarding the installation and use of the x-ray inspection systems.



ANRITSU INFIVIS INC. <http://www.detectionperfection.com>

1001 Cambridge Drive Elk Grove Village, IL 60007-2453
Phone (847) 419-XRAY (9729) Fax (847) 537-8266

© ANRITSU INFIVIS CO., LTD. 2014
ISO14001 CERTIFICATE No.JQA-EM0210
ISO 9001 CERTIFICATE No.JQA-0566



- Some products shown in this catalog may not be available in your country or region. Contact our sales representatives for details.
- To ensure proper operation, read the Operation Manual before using the machine.
- In addition to daily inspection, an annual maintenance check should be carried out.

Specifications are subject to change without notice.
No part of this catalog may be reproduced without our permission.